

# We are blind

There are none  
so blind as  
those who  
cannot see

Six blind men were asked to determine what an elephant looked like by feeling different parts of the elephant's body. The blind man who feels a leg says the elephant is like a pillar; the one who feels the tail says the elephant is like a rope; the one who feels the trunk says the elephant is like a tree branch; the one who feels the ear says the elephant is like a hand fan; the one who feels the belly says the elephant is like a wall; and the one who feels the tusk says the elephant is like a solid pipe.

A wise one explains to them:

"All of you are right. The reason every one of you is telling it differently is because each one of you touched the different part of the elephant. So, actually the elephant has all the features you mentioned."

This resolves the conflict.

## What do we mean "we can see?"

It's energy called "electromagnetic (EM) radiation" (but this kind of radiation is not harmful, except for an occasional sunburn). There are other kinds of EM radiation too (radio waves, microwaves, x-rays, etc.), but light is the part WE can see, the part that makes the rainbow.

EWSB



# We are blind

## The Electromagnetic Spectrum

Chart by LRSP/University of Colorado, Boulder

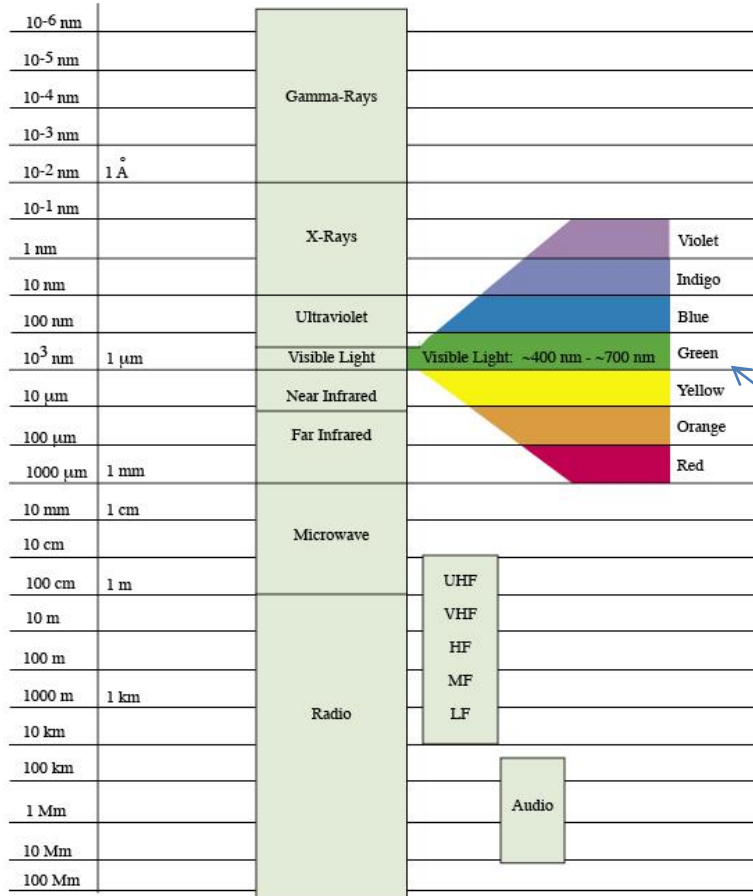

nm=nanometer, Å=angstrom, μm=micrometer, mm=millimeter,  
cm=centimeter, m=meter, km=kilometer, Mm=Megameter



Colours of the rainbow  
Are only a tiny fraction of the  
electromagnet spectrum

EWSB



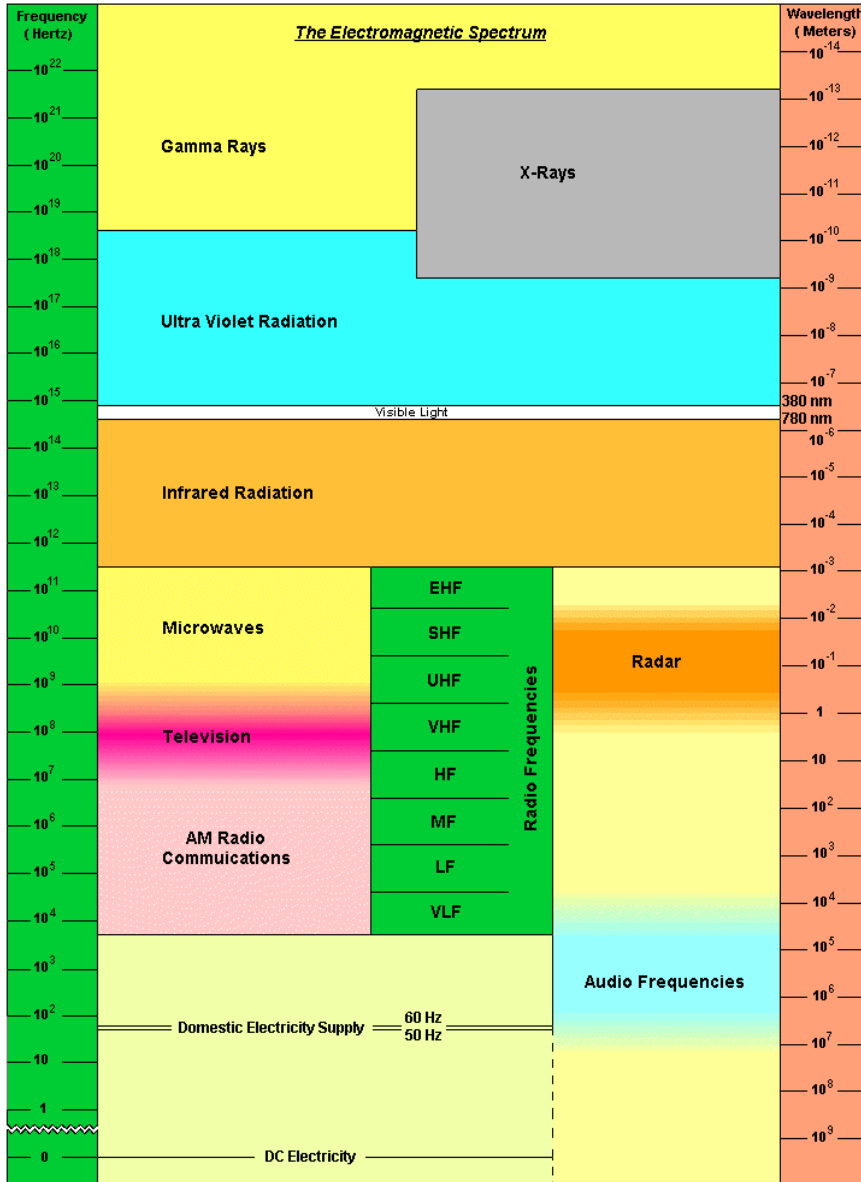

We are blind



EWSB



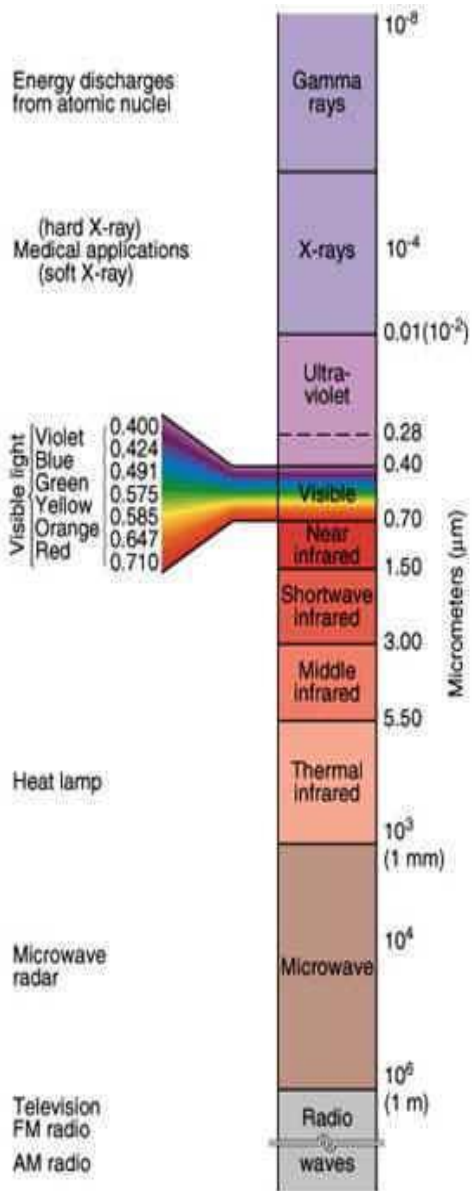

Slip slap saved by  
The earth's magnetic field  
And the ionosphere

Produced by the sun

Radiation from the sun in these frequencies. Incoming solar radiation impacts on a gas atom (or molecule). In the process, part of this radiation is absorbed by the atom and a free electron and a positively charged ion are produced.

EWSB



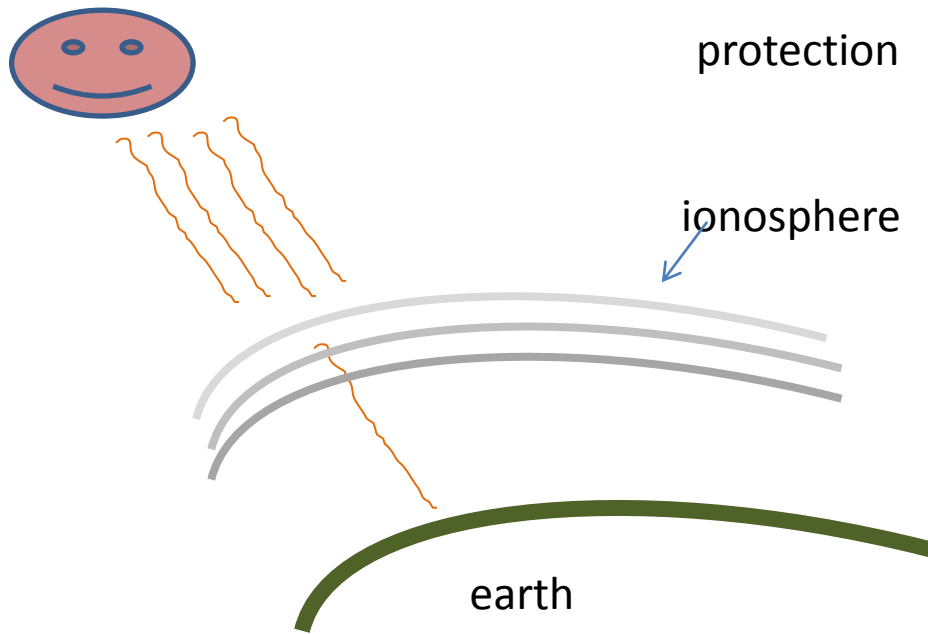

The ionosphere is the ionized component of the Earth's upper atmosphere. Two different ionization processes are involved in its creation: photoionization, principally by solar extreme ultraviolet (EUV) and x-ray photons, and impact ionization by charged particles (including solar and galactic cosmic rays).

EWSB



protection

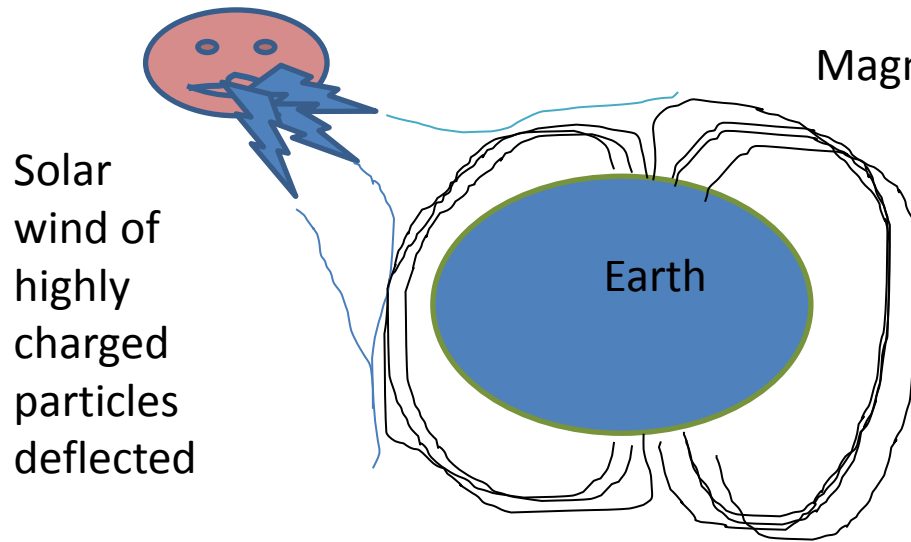

Solar  
wind of  
highly  
charged  
particles  
deflected

Magnetic field

The magnetic field of the Earth protects the planet from space radiation. The biggest culprit is the sun's solar wind. These are highly charged particles blasted out from the sun like a steady wind. The Earth's magnetic field channels the solar wind around the planet, so that it doesn't impact us. Without the magnetic field, the solar wind would strip away our atmosphere.

---

### ABC's "Ask the expert"

I was watching a movie on TV where a super solar flare was about to enter the Earth and destroy all living things on the planet. Could this happen?

"The short answer is no," says Dr David Neudegg, from the [Australian Ionospheric Prediction Service](http://www.ionosphericprediction.gov.au/), which monitors space weather.

"Solar flares do occur regularly but their impact on the Earth is considerably less dramatic than this movie. There is no evidence to suggest that they have ever had a destructive impact on life on Earth."

Solar flares are basically a release of energy from the Sun, and they usually happen around sunspots — which are small areas where the Sun's magnetic field is poking out of its surface in loops.

"The magnetic field loop breaks and releases light in the x-ray spectrum. This light takes eight minutes to get to the Earth where it is absorbed in the upper atmosphere or 'ionosphere' about 100 kilometres above us," says Neudegg.

<http://www.abc.net.au/science/articles/2011/11/23/3374013.htm?site=science/askanexpert&topic=space>

EWSB



# Long hop radio

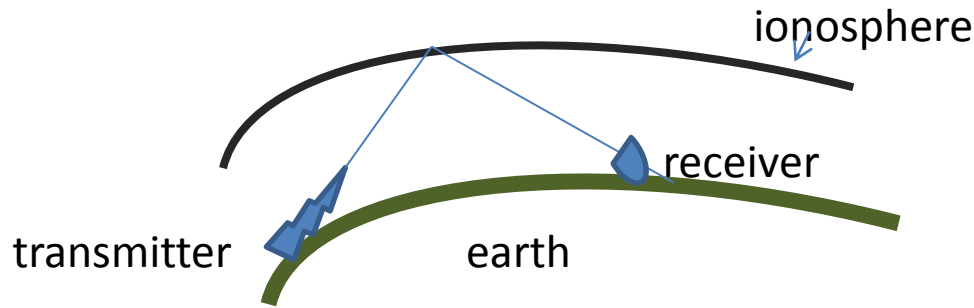

December 12, 1901, Marconi, who is often called the "Father of Wireless," demonstrated transatlantic communication by receiving a signal in St. John's Newfoundland that had been sent from Cornwall, England.

*Radio uses the ionosphere to  
bounce radio signals  
After all they are Electro –  
magnetic  
And the ionosphere is ionic*

**MAYBE A CAREER IN RADIO AWAITS YOU**

EWSB



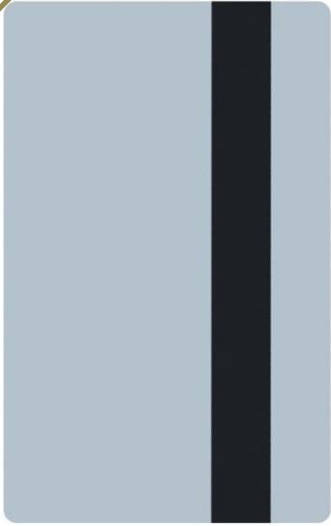

Credit card magnetic stripe



Crouzet travel card



Telstra Phone card



Smart card insert credit card



Touch and go

Radio-Frequency Identification

# What are the difference between all these cards



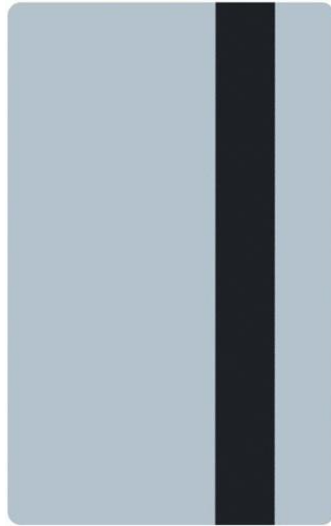

The Magnetic stripe is encoded with a strength of 300 Oersteds making it easier to copy



The Magnetic stripe is encoded with a strength of 22,000 Oersteds



**MAYBE A CAREER IN  
SMART  
CARDS AND BANKING  
AWAITS YOU**

An "Oersted" is a unit of magnetising fields names after Hans Christian Orsted





When the card is inserted contact is made with the smart chip

Java Cards are smart cards able to be programmed in Java

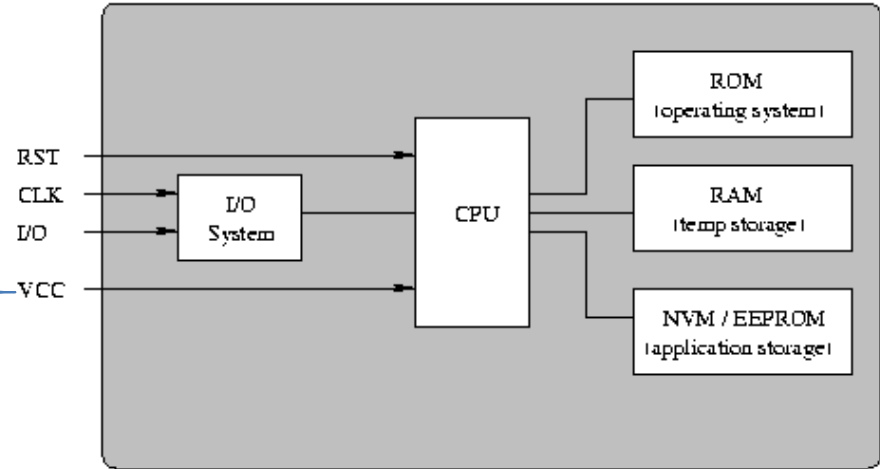

A cut down computer

Maybe a career in computing especially writing code to add loyalty and banking to smart card chips awaits you

EWSB



# electronics

**“ELECTRONICS an 'enabling technology' that provides our communications and entertainment, guards our health and safety and facilitates the creativity and productivity of our community. SA has a very strong electronics sector that specialises in the design and manufacture of defence, communication and instrumentation systems, sensors and medical devices.**

**“<http://www.tia.asn.au/careers>**



Vet in Schools  
Certificate 1 Electrotechnology

EWSB



Careers

in Acoustics, Airborne Electronics Analyst, Aircraft Instrument Mechanics and Inspectors, Airplane Navigators - Military, Appliance Service Technician, Assemblers - Electrical and Electronic Equipment, Audio and Video Equipment Technicians, Audio and video audio technicians, Audio video specialists,

# electronics

## Careers in

Camera repairer, cable TV installer, cable TV repairer, electronics technician, communications operator-military, computer machine repairer, computer service technician, electronics assemblers, electronic bench testers, electronic home entertainment equipment repairer, electronic instrument tradesperson, service technician, industrial designer, instrumentation, lighting technician, photonics technician, solar PV installer, radar and sonar technician, radio technician, recording engineer, robot technician, security alarm installer, sound effects editor, sound recording engineer, telecommunications career, TV engineer, TV technician, vehicle electronics technician, electronic sales and after sales set up.

EWSB

